

PATENTED ARM DESIGN

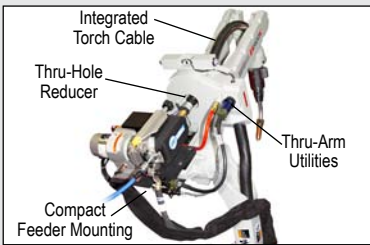

IMPROVED PART ACCESS



INTEGRATED UTILITIES

TOP REASONS TO BUY

- Higher payload arc welding robot with integrated torch cable
- Heavier payload robot can be used for non-welding applications such as dispensing
- Streamlined design improves torch access into tight spaces
- Patented multiple robot control allows more arms to be combined in workcell



MA1800

ARC WELDING

Payload: 15 kg

Mounting Options: Ceiling/Wall (MA1800T)

"Master Arc" Welding Robot Fast, Streamlined and Powerful

- Higher payload MA1800 "Master Arc" welding robot has the fastest speed in its class.
- Reduces welding cycle time due to cutting-edge Sigma V AC servo motor control technology and ARM (Advanced Robot Motion) control.
- 15 kg (33.1-lb) payload; 1,807 mm (71.1") reach; ± 0.08 mm (± 0.003 ") repeatability.
- Integrated through-the-arm torch cabling eliminates cable interference, simplifies programming and reduces cable wear.
- Feeder cable and welding gas can be routed through robot base to upper arm.
- Hollow upper arm maintains optimum bend radius of welding torch cable, maximizing weld performance. T-axis can rotate torch ± 200 degrees without cable interference.
- Regardless of torch orientation or part size or shape, prevents bent, pinched or stretched cables, minimizing wire feed problems and optimizing weld performance. Backed by industry's first two-year torch cable warranty.

- Floor-mounted model is standard. Ceiling- or wall-mounted versions (MA1800T) available.

DX100 Controller

- Patented multiple robot control supports up to 8 robots/72 axes.
- Windows® CE programming pendant with color touch screen and USB interface.
- DX100 welding full function arc welding software including graphics-based weld file settings.
- Faster processing speeds for smoother interpolation. Quicker I/O response. Accelerated Ethernet communication.
- Extensive I/O suite includes integral PLC and touch screen HMI, 2,048 I/O and graphical ladder editor.
- Supports all major fieldbus networks, including EtherNet/IP, DeviceNet, Profibus-DP and many others.
- Compliant to ANSI/RIA R15.06-1999 and other relevant ISO and CSA safety standards. Optional Category 3 functional safety unit.

MA1800 ROBOT

All dimensions are metric (mm) and for reference only. Please request detail drawings for all design/engineering requirements.

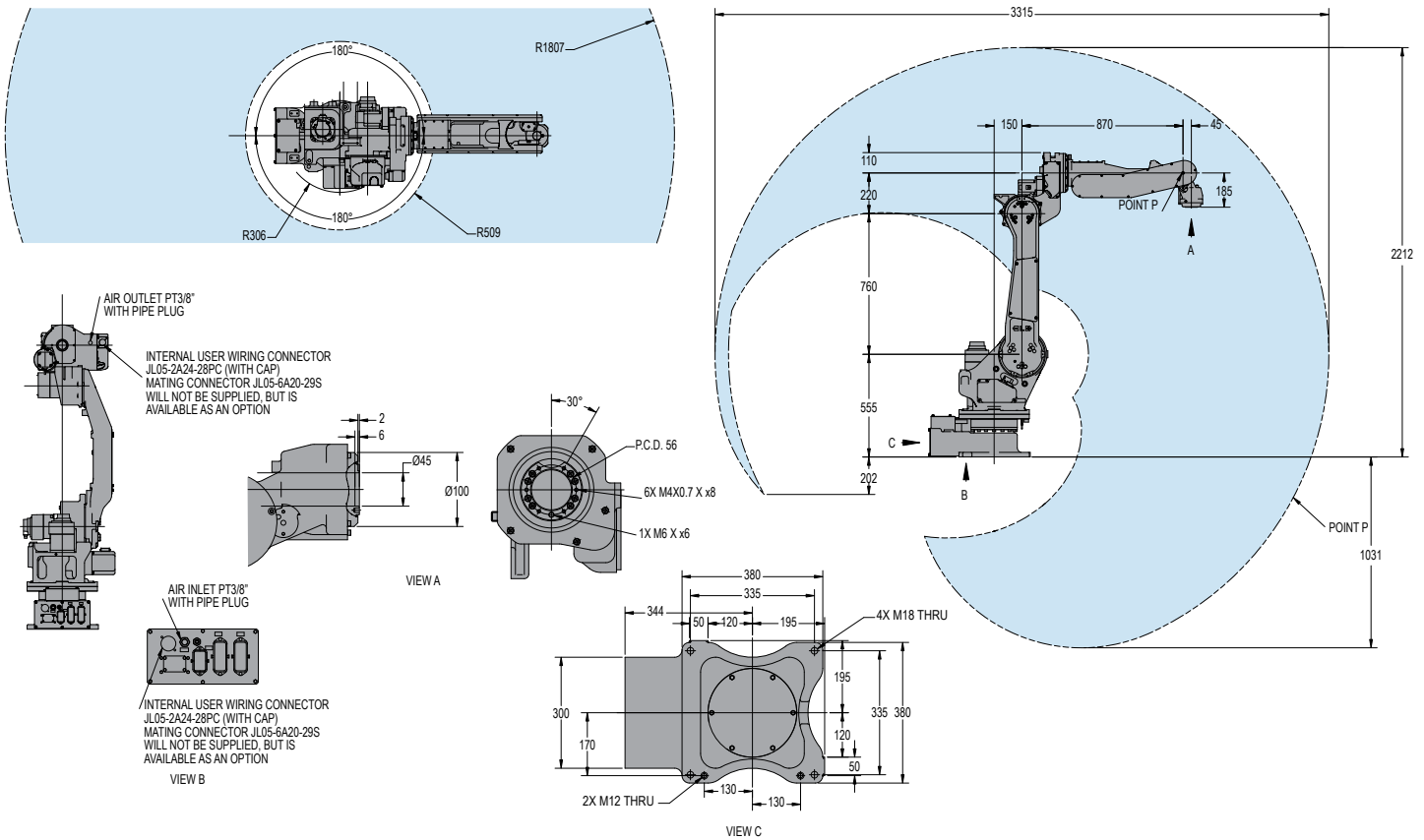

MA1800 SPECIFICATIONS

Structure	Vertical jointed-arm type	
Controlled Axes	6	
Payload	15 kg (33.1 lbs)	
Vertical Reach	3,243 mm (127.7")	
Horizontal Reach	1,807 mm (71.1")	
Repeatability	±0.08 mm (±0.003")	
Maximum Motion Range	S-Axis (Turning/Sweep) L-Axis (Lower Arm) U-Axis (Upper Arm) R-Axis (Wrist Roll) B-Axis (Bend/Pitch/Yaw) T-Axis (Wrist Twist)	±180° +155°/-100° +210°/-175° ±175° +180°/-45° ±200°
Maximum Speed	S-Axis L-Axis U-Axis R-Axis B-Axis T-Axis	195°/s 175°/s 190°/s 380°/s 340°/s 560°/s
Approximate Mass	380 kg (837.9 lbs)	
Brakes	All axes	
Power Consumption	5 kVA	
Allowable Moment	R-Axis B-Axis T-Axis	38.6 N • m 38.6 N • m 7.35 N • m
Allowable Moment of Inertia	R-Axis B-Axis T-Axis	1.04 kg • m ² 1.04 kg • m ² 0.04 kg • m ²

DX100 CONTROLLER SPECIFICATIONS**

Dimensions (mm)	800 (w) x 1,000 (h) x 650 (d) (31.5" x 39.4" x 25.6")
Approximate Mass	250 kg max. (551.3 lbs)
Cooling System	Indirect cooling
Ambient Temperature	During operation: 0° to 45° C (32° to 113° F) During transit and storage: -10° to 60° C (14° to 140° F)
Relative Humidity	90% max. non-condensing
Primary Power Requirements	3-phase, 240/480/575 VAC at 50/60 Hz
Digital I/O	Standard I/O: 40 inputs/40 outputs consisting of 16 system inputs/16 system outputs, 24 user inputs/24 user outputs 32 Transistor Outputs; 8 Relay Outputs Max. I/O (optional): 2,048 inputs and 2,048 outputs
Position Feedback	By absolute encoder
Program Memory	JOB: 200,000 steps, 10,000 instructions CIO Ladder Standard: 15,000 steps Expanded: 20,000 steps
Pendant Dim. (mm)	169 (w) x 314.5 (h) x 50 (d) (6.7" x 12.4" x 2")
Pendant Weight	.998 kg (2.2 lbs)
Interface	One Compact Flash slot; One USB port (1.1)
Pendant Playback Buttons	Teach/Play/Remote Keyswitch selector Servo On, Start, Hold, and Emergency Stop Buttons
Programming Language	INFORM III, menu-driven programming
Maintenance Functions	Displays troubleshooting for alarms, predicts reducer wear
Number of Robots/Axes	Up to 8 robots, 72 axes
Multi Tasking	Up to 16 concurrent jobs, 4 system jobs
Fieldbus	DeviceNet Master/Slave, AB RIO, Profibus, Interbus-S, M-Net, CC Link, EtherNet IP/Slave
Ethernet	10 Base T/100 Base TX
Safety	Dual-channel Emergency Stop Pushbuttons, 3-position Enable Switch, Manual Brake Release Meets ANSI/RIA R15.06-1999, ANSI/RIA/ISO 10218-1-2007 and CSA Z434-03

**See DX100 Controller data sheet (DS-399) for complete specifications

www.motoman.com

MOTOMAN ROBOTICS
100 AUTOMATION WAY, MIAMISBURG, OHIO 45342
TEL: 937.847.6200 ■ FAX: 937.847.6277

YASKAWA

MOTOMAN ROBOTICS

TECHNICAL SPECIFICATIONS SUBJECT TO CHANGE WITHOUT NOTICE
DS-451-B ©2011 YASKAWA AMERICA, INC. JUNE 2011

MOTOMAN IS A REGISTERED TRADEMARK
WINDOWS IS A REGISTERED TRADEMARK OF MICROSOFT
ALL OTHER MARKS ARE THE TRADEMARKS AND
REGISTERED TRADEMARKS OF YASKAWA AMERICA, INC.